



Upstream pressure relief automatic valve Mod. XLC 320/420-R

The CSA Model XLC 320/420-R is a globe pattern hydraulically operated automatic control valve that, installed in derivation from the main line, will relieve the excessive upstream pressure when it rises above the pre-set and adjustable value. Normally equipped with visual position indicator and entirely made in ductile cast iron with FBT epoxy coating and stainless steel, the valve is designed to reduce head loss, throttling noise and cavitation damage. The CSA pressure relief valve XLC 320/420-R is extremely versatile and can be used for a wide range of applications in combination with several CSA accessories and additional functions.

Applications

- Downstream of pumps to protect the pipeline against rise in pressure during pump start up and pump failure.
- As a protection against rise in pressure in industrial equipment and civil installations.
- Downstream of pressure reducing station and modulating devices to protect the system against unwanted pressure fluctuations.

Accessories

- Linear position transmitter with 4-20 mA output Mod. CSA CSPL.
- On-off position transmitter Mod. CSA CSPO.
- Pressure measurement kit.
- Self-flushing and high capacity filter.

Note to the engineer

- Inlet pressure, outlet pressure, flow rate and application are required for the proper sizing and cavitation analysis.
- For the recommended flow rate, and operating conditions, please use the charts available on the XLC series engineering.
- When the valve discharges to atmosphere the AC (anti-cavitation) system is advised.

Additional features

- XLC 320/420-R-FR upstream pressure relief valve with back-flow prevention.
- XLC 320/420-R-5 upstream pressure relief valve with solenoid control.
- The valve can be supplied without the GR.I.F.O. to increase the reaction time.

Working conditions

- Fluid: treated water.
- Minimum operating pressure: 0,7 bar.
- Maximum operating pressure: 25 bar.
- Maximum temperature: 70°C.

Pressure relief pilot adjustment range

- Blue spring: 0,7 to 7 bar.
- Red spring: 1,5 to 15 bar.
- Higher values up to 25 bar on request.

Operating principle

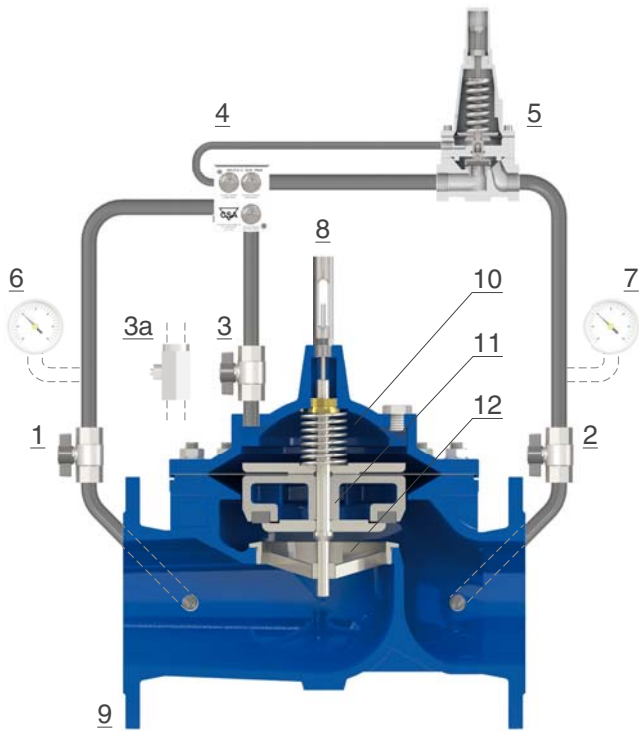

The CSA Model XLC 320/420-R is an automatic control valve operated by a high flow capacity two ways pilot (5), with pre-set and adjustable set point value, sensing the upstream pressure from the GR.I.F.O. (4). Should the line pressure rise above the pilot's set point the latter will open thus relieving the chamber (10) and moving the obturator (11) upwards, to discharge water and pressure through the main valve (9) downstream protecting the system. Should the upstream pressure be lower than the pilot's set point the latter will throttle (close eventually) diverting all pressure towards the main chamber (10) thus pushing the obturator (11) onto the seat (12), interrupting the flow rate.

The flow in and out of the main chamber is controlled by the CSA exclusive unit flow GR.I.F.O. (4) providing accuracy and absence of unwanted chattering.

Installation layout

The picture below shows the recommended installation lay-out of the CSA XLC 320/420-R, used as a pressure relief in derivation from the main line to protect a pumping station. The sectioning devices are very important for maintenance operations; whenever possible a filter too is needed to prevent dirt from reaching the control valve. The set point should always remain within 0,5-1 bar above the maximum steady state pressure value of the pumps.

