



## Upstream pressure relief surge anticipating control valve Mod. XLC 321/421

The CSA Model XLC 321/421, installed in derivation from the main line, will act as a protection of the system against the devastating effects of water hammer caused by pump failure. Thanks to a circuit composed of two pilots, hydraulic accelerators and CSA exclusive flow control stabilizer, the valve will serve both as a pressure relief, in case of rise of pressure, and as an anticipator of water hammer in case of pump failure providing the valve with a response time almost instantaneous. For the proper sizing and water hammer analysis please contact CSA.

### Applications

- At the pumping stations, downstream of pumps check valves in derivation from the main line.
- The valve is usually associated to CSA anti-surge combination air valves FOX 3F AS and other CSA products chosen by the water hammer analysis.

### Accessories

- Linear position transmitter with 4-20 mA output Mod. CSA CSPL.
- On-off position transmitter Mod. CSA CSPO.
- Pressure measurement kit.
- Self-flushing and high capacity filter.
- CSFL mechanical flow regulator.

### Note to the engineer

- For the recommended flow rate, and operating conditions, please use the charts available on the XLC series engineering.
- CSA needs the project data for a surge analysis which is highly recommended for the sizing and setting of XLC 321/421.
- The AC (anti-cavitation) system is always recommended for this kind of valve.

### Working conditions

- Fluid: treated water.
- Minimum operating pressure: 1,5 bar.
- Maximum operating pressure: 25 bar.
- Maximum temperature: 70°C.

### Upstream pressure pilot adjustment range

- Blue spring: 0,7 to 7 bar.
- Red spring: 1,5 to 15 bar.
- Higher values up to 25 bar on request.

### Pressure relief pilot adjustment range

- Red spring: 1,5 to 15 bar.
- Higher values up to 25 bar on request.

## Operating principle

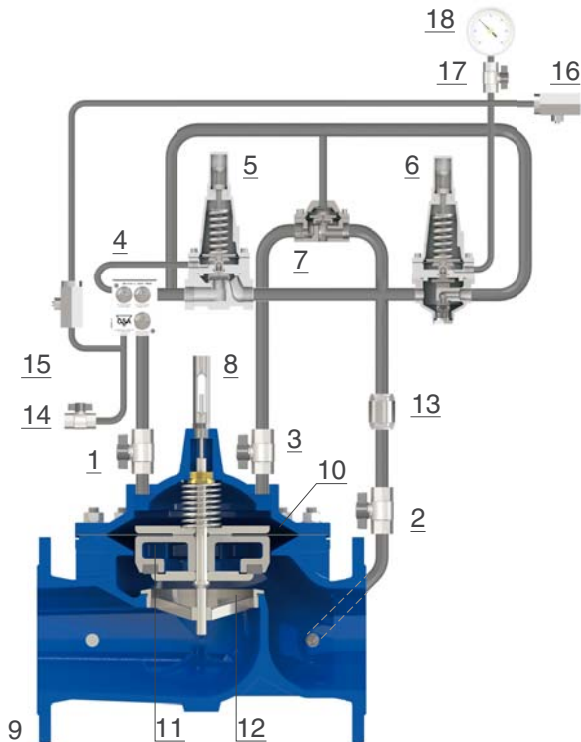

The circuit is sensing the pressure of the main line through a dedicated pressure port (14). Two pilots, one for high pressure (5) and the second for low pressure (6), are both pre-set according to the results of the water hammer analysis. Should the upstream pressure rise above the high pressure pilot (5) the latter will open putting the main chamber (10) in communication with the downstream boundary condition (usually atmosphere, tank or other lower pressure values) thus pushing the obturator upwards in order to open the main valve (9) and discharge the exceeding pressure. Should the pump trip due to power failure the lower pressure pilot (6) will first sense the decrease in pressure, to allow flow through the accelerator (7) and relieve pressure of the control chamber (10), thus causing the opening of the main valve (9) with a response time almost immediate. Needle valves (15 and 16) are used for the proper regulation and set up. The flow in and out of the main chamber is controlled by the flow stabilizer GR.I.F.O. (4) providing accuracy and absence of chattering.

## Installation layout

The installation lay-out of the CSA XLC 321/421, used as a protection device in derivation from the main line includes sectioning devices, very important for maintenance operations. Whenever possible a filter too is needed to prevent dirt from reaching the control valve. Anti-surge combination air valves CSA Mod. FOX 3F AS are advised near the XLC 321/421 to avoid negative pressure conditions (if likely to occur), and also used as a static pressure sensing port for the circuit through their drainage valve.

