



Minimum-maximum level automatic control valve Mod. XLC 340/440

The CSA Model XLC 340/440 is a globe pattern hydraulically operated automatic control valve that regulates the minimum-maximum level of a tank, with an adjustable range, regardless of upstream pressure variations. Thanks to a CSA needle valve the response time can be regulated, to prevent water hammer effects during the closing phase. Normally equipped with visual position indicator and entirely made in ductile cast iron with FBT epoxy coating and stainless steel, the valve is designed to reduce head loss, throttling noise and cavitation damage.

Applications

- On storage tank to perform a minimum and maximum control, decreasing the operating cycles and therefore maintenance, using at the same time most of the storage capacity.
- For level control with an external container should the main tank not be accessible.
- On rooftop and elevated reservoir in general where level control is maintained through pumps operations, and an hydraulic backup is needed to avoid overflow.

Accessories

- On-off position transmitter Mod. CSA CSPO.
- Pressure measurement kit.
- Self-flushing and high capacity filter.
- CSA anti-cavitation low flow stability plugs are recommended to provide an accurate regulation in case of low flow conditions.
- CSFL mechanical flow regulator.

Note to the engineer

- Avoid bends and high points on the piping to connect the main valve to the level control pilot to prevent the formation of air pockets.
- A minimum of 0,6 bar on the pilot is needed, failing in doing so would create delays and malfunctioning. Consider the use of a sustaining pilot for low pressure conditions and/or the CSFL mechanical flow regulator.

Additional features

- XLC 340/440-FR minimum maximum level control with back-flow prevention.
- XLC 445 minimum maximum level control with solenoid control.
- XLC 340/440-R minimum maximum level control with surge prevention pilot.

Working conditions

- Fluid: treated water.
- Minimum operating pressure: 0,6 bar on the pilot.
- Maximum operating pressure: 16 bar.
- Recommended working pressure: 6 bar. Higher on request.
- Maximum temperature: 70°C.

Min.-max. level control pilot adjustment range

- Between 0,2 and 4 meters.

Operating principle (for DN 150-600)

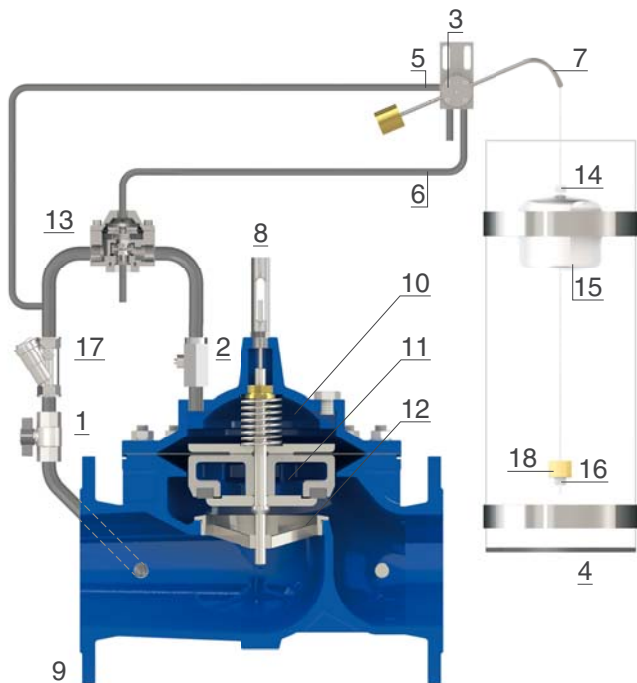

The CSA valve model XLC 340/440 is operated by a 3 ways pilot connected to the valve by means of two pipes, not supplied. The level control pilot, entirely made in stainless steel, is composed of a body (3), lever (7), float (15) and wire, and contains two mechanical blocks adjustable and set to the required level (14 and 16). Should the latter reach the maximum level the float (15) moves the upper block (14) upwards, to rotate the lever (7) thus allowing the closing of the valve by putting the upstream pressure in communication with the chamber of the valve (10) or the hydraulic accelerator (13) (available from DN 150 and above). The valve remains closed until the level drops to the lower set point (16) which enables the rotation of the lever (7) putting the chamber (10 or 13) in communication with the atmosphere, thus raising the obturator (11) to generate flow through the seat (12). A needle valve on the chamber (2) will control pressure and flow in and out to prevent surges during closure.

Installation layout

The picture shows the layout of the XLC 340/440 minimum-maximum level control valve. The connection between the valve and the pilot (4) is obtained by means of two pipes, one linked to the upstream pressure and the other to the chamber. Sectioning devices (1) and filter (3) are needed for maintenance operations and to prevent dirt from entering the main valve. The external stilling container (2), strongly advised, allows for the proper control reducing turbulence of the water surface without having to access the tank.

