



## Step by step solenoid control valve Mod. XLC 353/453

The CSA Model XLC 353/453 is a globe pattern hydraulically operated automatic control valve that modulates in response to signals applied to the solenoids valves. Thanks to CSA needle valves located on the circuit the reaction time of the opening and closing can be adjusted, independently one from the other, to ensure a smooth and accurate regulation. A manual emergency circuit is usually supplied with valve in case of power failure. Normally equipped with 4-20 mA position transmitter and made in ductile cast iron with FBT (fluid bed technology) epoxy coating and stainless steel, the valve reduces head loss, throttling noise and cavitation damage.

### Applications

- In combination with CSA controllers for pressure management and leakage reduction to regulate pressure versus flow.
- On the inlet supply line of storage tanks to perform level regulation and control.
- On the outlet supply line of storage tanks for flow control as a function of the water level.
- On heating and cooling systems to ensure flow control according to the temperature.

### Accessories

- Linear position transmitter Mod. CSA CSPL.
- On-off position transmitter Mod. CSA CSPO.
- Pressure measurement kit.
- Self-flushing and high capacity filter.
- CSFL mechanical flow regulator.

### Note to the engineer

- CSA anti-cavitation low flow stability plugs are recommended to provide an accurate regulation in case of low flow conditions.
- Recommended flow rate and operating conditions on the XLC series engineering.
- The duration of impulses sent to the solenoid is important and changes with valve size and operating pressure.

### Additional features

- XLC 353/453-FR step by step solenoid control valve with back-flow prevention system.
- XLC 353/453-5 step by step solenoid valve with emergency opening system from remote.
- XLC 353/453-R step by step solenoid control valve with surge control system.

### Working conditions

- Fluid: treated water.
- Minimum operating pressure: 1,5 bar.
- Maximum operating pressure: 16 bar. Higher on request.
- Maximum temperature: 70°C.

### Solenoid electrical data

- Voltages: 24 V DC, 24 V/50 Hz, 230 V/50 Hz. Other voltages on request.
- Power consumption: inrush AC (VA) 24, hold AC (VA) 17 (8 W), DC hot/cold coil 8/9 W.

## Operating principle

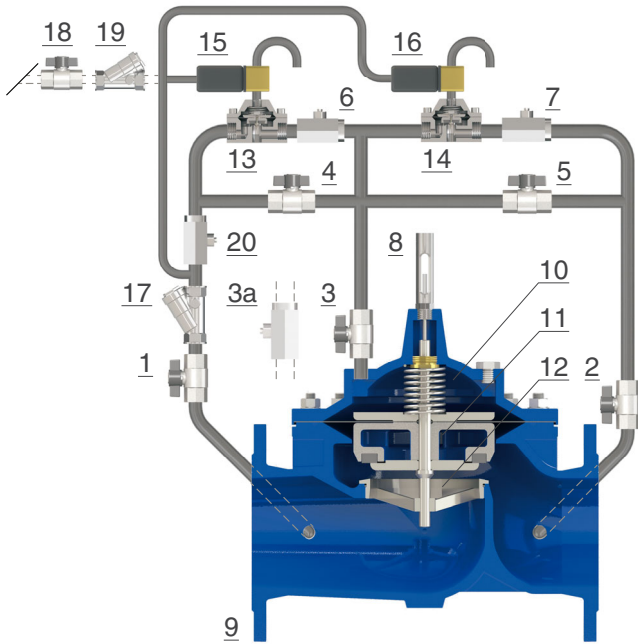

The model XLC 353/453 includes two solenoids (15-16) receiving impulses and acting on hydraulic accelerators (13-14), normally closed. Should a signal be sent to the upstream solenoid (15), the latter will allow some flow through (13) and towards the main chamber (10), in proportion to the numbers and duration of such impulses and controlled by the needle valve 6, throttling the passage between obturator (11) and seat (12). In the same way by using the downstream solenoid (16) water will be taken out of the main chamber, with flow and the opening speed controlled by the needle valve (7).

The main valve will therefore modulate in response to the signals sent to both solenoids.

The manual circuit (4-5) is always supplied, unless otherwise stated, and necessary to regulate the valve in case of power failure. A filter (3) will protect the solenoid and the rest of components to prevent dirt from entering the mechanical assemblies.

We recommend to connect the pressure sensing line upstream as shown in the picture (18, 19).

## Installation layout

In the picture the XLC 353/453 is installed in combination with a flow meter (5). A CSA controller (8) or other PLC units will constantly send impulses to the valve's solenoids to maintain the same flow regardless of pressure variations, or to manage the pressure according to variations in demand to reduce water loss and leakage. Sectioning devices (1, 2) and a by-pass, with CSA direct acting valves (4), are important for maintenance as well as a filter (3) and anti-surge air valves FOX 3F AS (6, 7) upstream and downstream.

